

**HOLE IN SHIPS  
STEEL WALL**

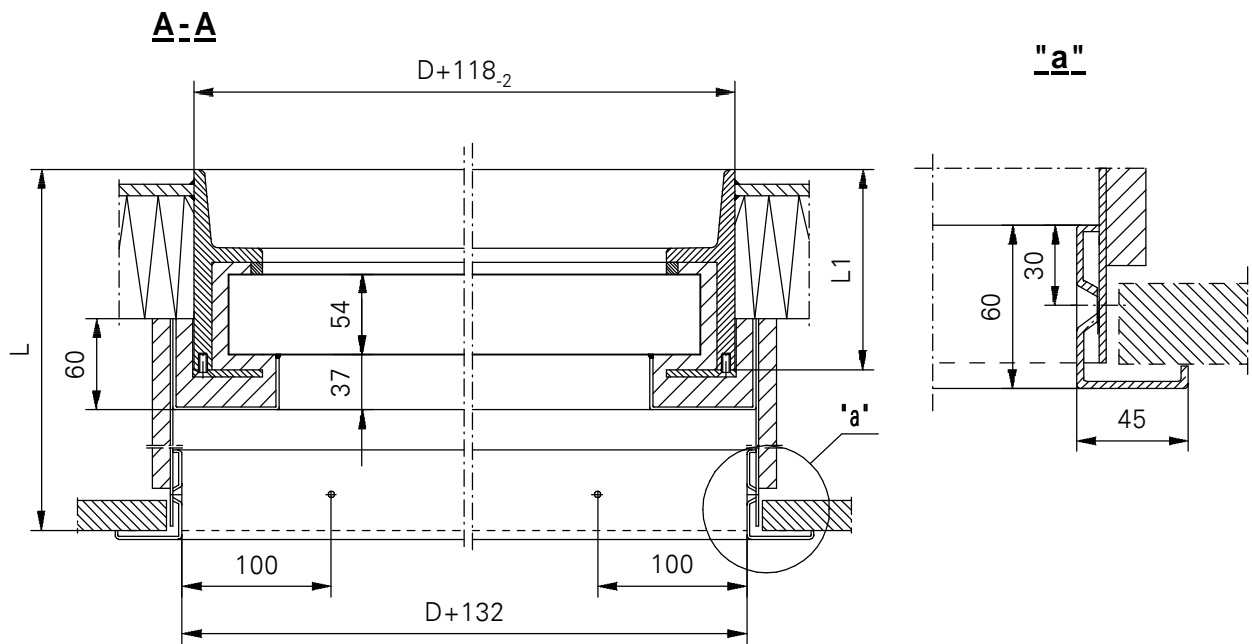

D	Mass (kg)
200	21,8
250	26,8
300	32,0
350	37,5
400	43,3

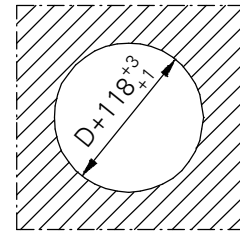

**LUBMOR Ltd.**

ul. Wieleńska 1, 64-980 Trzcianka  
 tel. +48/67/216-22-44  
 fax +48/67/216-59-40  
 e-mail: marketing@lubmor.pl  
 e-mail: konstrukcja@lubmor.pl

**SIDE SCUTTLE CLASS A60**

**KI 24-99  
30-300**

## **SIDE SCUTTLE CLASS A60**

### **APPROPRATION**

Side scuttles class A60 are designed for using on the water ships .

### **EXECUTION**

Side scuttle is made according to Polish and international standard requirements .

Side scuttle is made of steel frame cover , set of glasses and side scuttle box . The frame is connected with cover by screws .

Space between glass , frame and side scuttle box is filled of fire proof insulation .

Fire proof glass is mounted with hardened glass pane of standard thickness 10 mm . Total thickness of glasses set and depth of frame depends of hardened glass pane .

This glass should be stated during order of side scuttle in case of orderer's requirements in order to the glass thickness was other than standard .

Side scuttle box is made of steel sheet thick. 2 mm . Exact size L is settled during mounting of side scuttle by means of frame screwing it with stainless steel self-tapping screws A3,9 x 22 acc. to DIN 7982 (12 pcs) .

Main side scuttle frame is protected against corrosion with epoxy primer thick. 40  $\mu\text{m}$  . The place covered of insulation is protected with painting set which consist three epoxy paints total thick. 100  $\mu\text{m}$  .

Visible surfaces are finished of white stove paint .

### **DELIVERY RANG**

Complete side scuttle together with the box but without screws is delivered to the customer .

### **PACKING , TRANSPORT , STORAGE**

The glass pane is protected with foil .

This foil is removed after mounting of side scuttle on the ship .

The side scuttles are delivered on the pallets without packing .

The goods should be transported of dry , clean and lidded trucks in order to avoid dislocation and mechanical damages .

They should also be stored in closed accommodations at the conditions like in transport and protected against the agents which might to cause a gasket damages .

### **EXAMPLE OF DESIGNATION**

Side scuttle class A60 size clear opening D – 400 mm , boarding thick. L = 200 mm acc. to catalogue card KK 24-00/30-300.

SIDE SCUTTLE A60 400 L = 200 acc. to information card KI 24-99/30-300.

This catalogue card corresponds with drawing no N 24-98/30-300.