

KIND OF THE EQUIPMENT

1	2	3
4	5	6
Item no	Name, standard marking	
1	Bracket for lock	
2	Bolt rim lock 3240Z-100228-left hand door-Schwepper Bolt rim lock 3240Z-100227-right hand door	
3	Catch-bolt rim lock 3827Z-109159-left hand door-Schwepper Catch-bolt rim lock 3827Z-109161-right hand door	
4	Handles set 2210-110817-Schwepper	
5	Cylinder cover 4577 ZK-Schwepper	
6	Escutcheon 6645/Z/2/75-Schwepper	
7	Closure for padlock	
8	Cylindrical bolt with hexagon seat DIN 127	

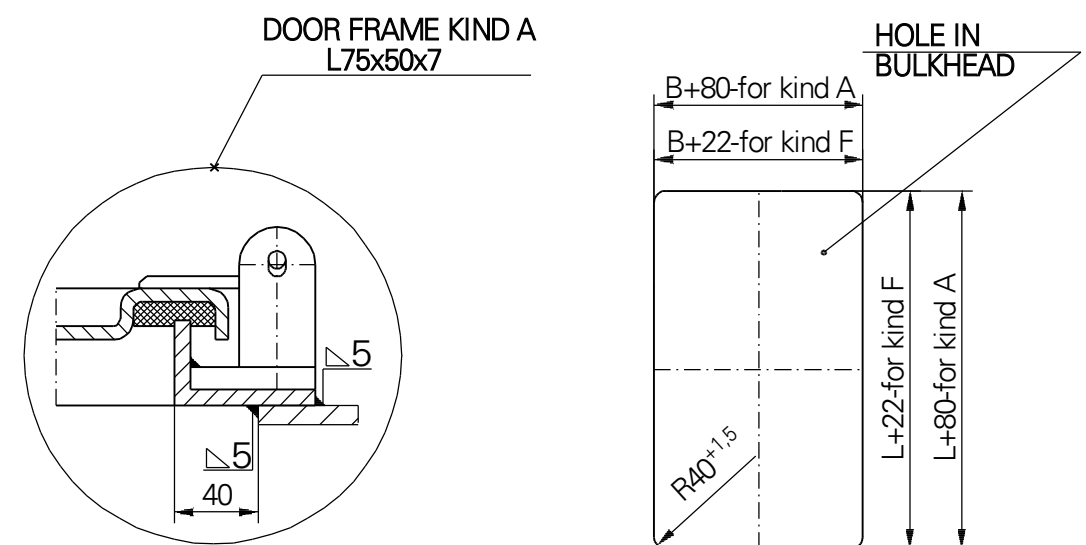

Nominal dimension	Dimension		Mass (kg)
	L	B	
1350 x 680	1329	659	89
1400 x 680	1379	659	94
1680 x 680	1659	659	108
1880 x 680	1859	659	118
1680 x 830	1659	809	121
1880 x 830	1859	809	134



LUBMOR Ltd.

ul. Wieleńska 1, 64-980 Trzcianka
tel. +48/67/216-22-44
fax +48/67/216-59-40
e-mail: lubmor@lubmor.pl
www.lubmor.pl

**SPRAY-TIGHT SINGLE-LEAF
STEEL DOOR**

**KK 24-05
34-921/B**

SPRAY - TIGHT SINGLE - LEAF STEEL DOOR

GENERAL PROVISION

- Doors are constructed and made on the base of regulations and standards as below :
- Ships and marine technology – Weathertight single – leaf steel door ISO 6042 : 1998
 - International standard – Ships and marine technology – Single – leaf external door – clear opening PN-ISO 3796-1996
 - Ship tight door – clear opening BN – 78/3712 – 17
 - Spray – tight single – leaf steel door BN – 82/3712 – 17.04
 - Heavy hinged doors for ships – DIN 83102

APPROPRATION

The doors are mainly suitable in steel bulkheads of ship.

EXECUTION

Door – leaf construction ensures a full stiffness by pressing of flange.

There is used an individual shutting and the hinges with regulated gap on the door opposite side to the hinges.

The elements which are exposed to friction (pins, sleeves) are made of stainless steel.

DELIVERY RANG

Delivery comprises a set with fittings acc. to specification as below .

DIVISION, MARKING AND FINISHING

Varieties :

- R - right - hand as shown on drawing
- L - left – hand as reflected

Kinds:

- without porthole – no marked
- P - with porthole ø 250
- O - with window 300x400

Kinds of door – frames :

- F - shape of door – frame – flat bar 70 x 10
- A - shape of door – frame – angle bar 75 x 50 x 7

Kind of the equipment acc. to detail x :

- 1 - without equipment
- 2 - closure for padlock
- 3 - bolt rim lock
- 4 - catch – bolt rim lock
- 5 - closure for padlock and bracket for lock
- 6 - closure for padlock and rim lock

Kind of door – leaf :

- non insulated – no marked
- W - Insulated

Finishing :

- door – leaf and door – frame painted twice of epoxy primer total thick. 40 µm. A channel under seal is additional painted of thick – covered epoxy paint total thick. 120 µm – no marked
- Zn - all the door hot galvanized of zinc coating thick. 25 µm

EXAMPLE OF MARKING

Spray – tight single – leaf, steel door, size 1350 x 680 mm right - hand, door - frame of flat bar, catch - bolt rim lock, closure for padlock door - leaf non insulated, painted .

SPRAY – TIGHT SINGLE – LEAF STEEL DOOR 1350 x 680 – R – F – 6 acc. to **KK24-05/34-921/B**.

At the doors weights aren't included an additional equipment (lock).

This catalogue card corresponds with drawing no N24-05/34-921/B rev. C