

KIND OF THE EQUIPMENT

1	2	3
Item no	Name, standard marking	
1	Bracket for lock	
2	Bolt rim lock 3240Z-100228-left hand door-Schwepper Bolt rim lock 3240Z-100227-right hand door	
3	Catch-bolt rim lock 3827Z-109159-left hand door-Schwepper Catch-bolt rim lock 3827Z-109161-right hand door	
4	Handles set 2210-110817-Schwepper	
5	Cylinder cover 4577 ZK-Schwepper	
6	Escutcheon 6645/Z/2/75-Schwepper	
7	Closure for padlock	
8	Cylindrical bolt with hexagon seat DIN 127	

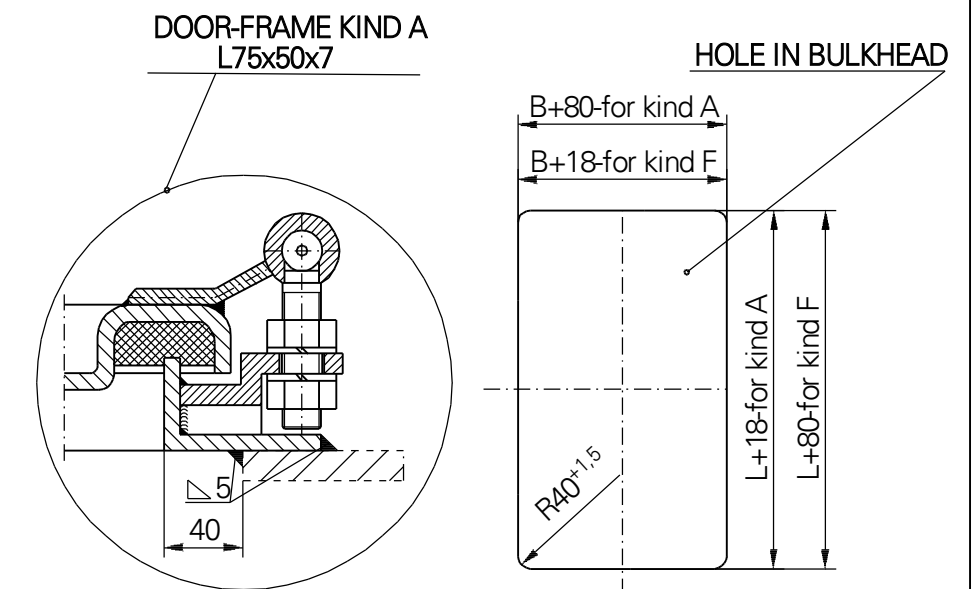

B \ L	600	750	900
	Mass (kg)		
1200	96	115	134
1400	108	130	152
1600	120	145	170
1800	132	160	188



LUBMOR Ltd.

ul. Wieleńska 1, 64-980 Trzcianka
tel. +48/67/216-22-44
fax +48/67/216-59-40
e-mail: lubmor@lubmor.pl
www.lubmor.pl

**WEATHERTIGHT SINGLE-LEAF
STEEL DOOR**

**KK 24-05
34-922/A**

WEATHERTIGHT SINGLE-LEAF STEEL DOOR

GENERAL PROVISIONS

- Doors are constructed and made on the base of regulations and standards as below :
- Ships and marine technology – Weathertight single – leaf steel door ISO 6042 : 1998
 - International standard – Ships and marine technology – single – leaf external door – clear opening PN-ISO 3796-1996
 - Ship tight door – clear opening BN – 78/3712 – 17
 - Stream – tight, single – leaf steel door BN – 80/3712 – 17.01
 - Heavy hinged doors for ships – DIN 83100.

APPROPRATION

The doors are mainly suitable for mounting in steel bulkheads of ship.

EXECUTION

Door – leaf construction ensures a full stiffness by pressing of flange.

There is used an central shutting and the hinges with regulated gap on the door opposite side to the hinges.

The elements which are exposed to a friction as : pins, sleeves, closures are made of stainless steel. In case if the doors are made with porthole, the hardened glass thick. 12 mm is used.

DELIVERY RANG

Delivery comprises a set with fittings acc. to specification as below .

DIVISION, MARKING AND FINISHING

Varieties :

L - left – hand door as shown on drawing

R - right – hand door as reflected

Kinds :

- without porthole – no marked

P - with porthole Ø 200

Kinds of door – frames :

F - shape of door – frame – flat bar 70 x 8

A - shape of door frame – angle bar 75 x 50 x 7

Kind of the equipment acc. to detail x :

1 - without equipment

2 - closure for padlock

3 - bolt rim lock

4 - catch – bolt rim lock

5 - closure for padlock and bracket for lock

6 - closure for padlock and rim lock

Kind of door – leaf :

- non insulated – no marked

W - insulated

Finishing :

- door – leaf and door – frame painted twice of epoxy primer total thick. 40 µm. A channel under seal is additional painted of thick – covered epoxy paint total thick. 120 µm – no marked

Zn - all the door hot galvanized of zinc coating thick. 25 µm

EXAMPLE OF MARKING

Weathertight single-leaf steel door , size 1600 x 750, left – hand, without porthole, door – frame of flat bar, catch – bolt lock, closure for padlock, door – leaf non insulated, painted.

WEATHERTIGHT SINGLE-LEAF STEEL DOOR 1600x 750 – R – A – 6 acc. to KK24-05/34-922/A.

At the doors weights aren't included an additional equipment (lock, porthole).

This catalogue card corresponds with drawing no N24-05/34-922/A.