

View from outside
Type IV

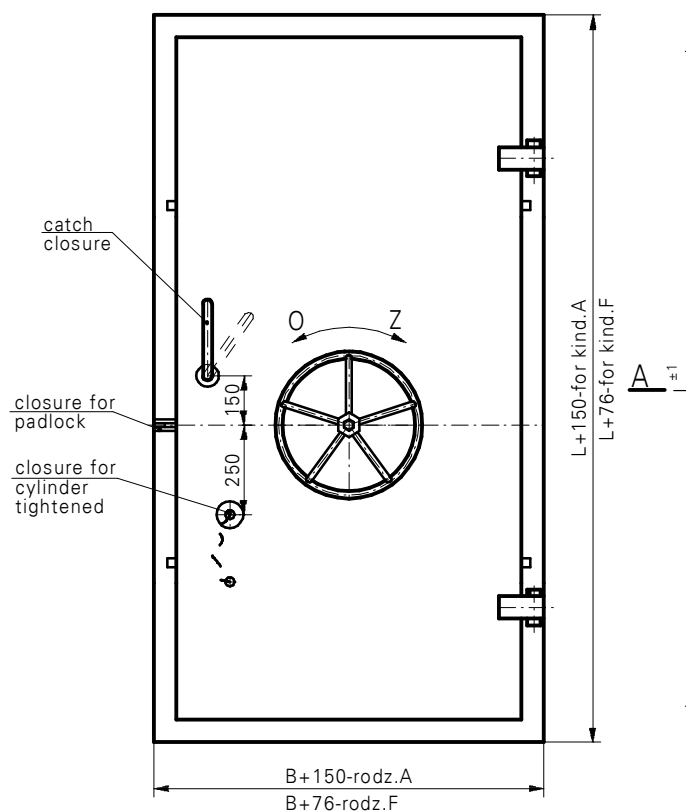

View from inside
Type IV

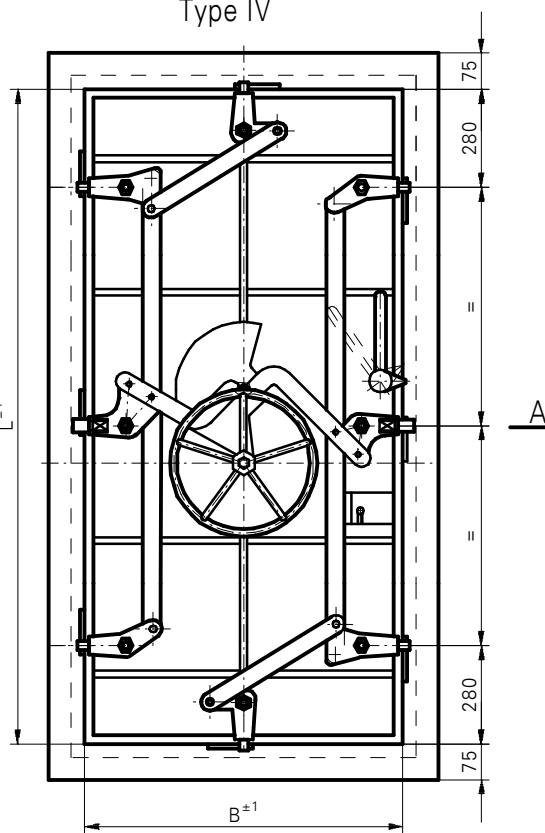

Types of doors

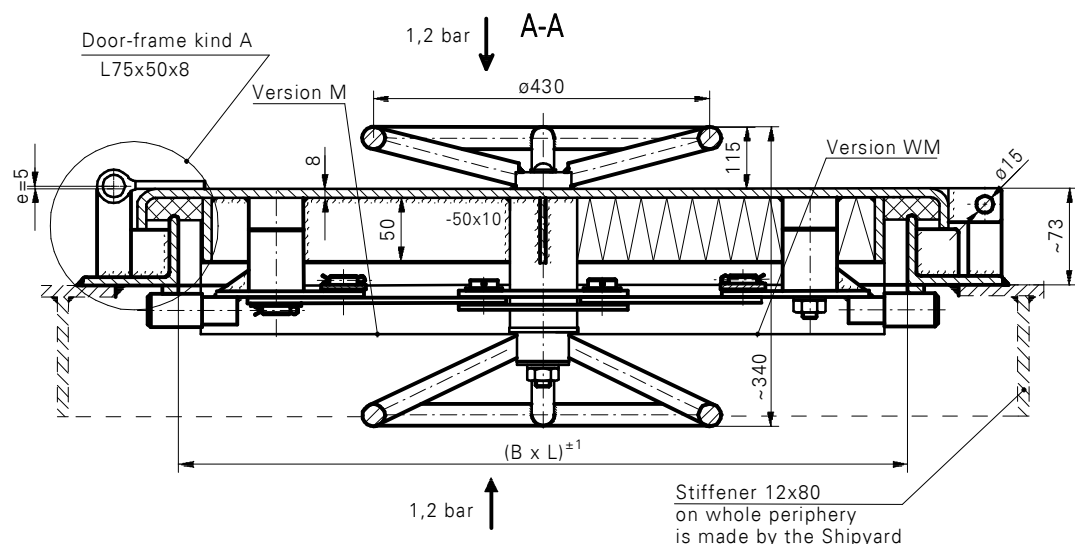
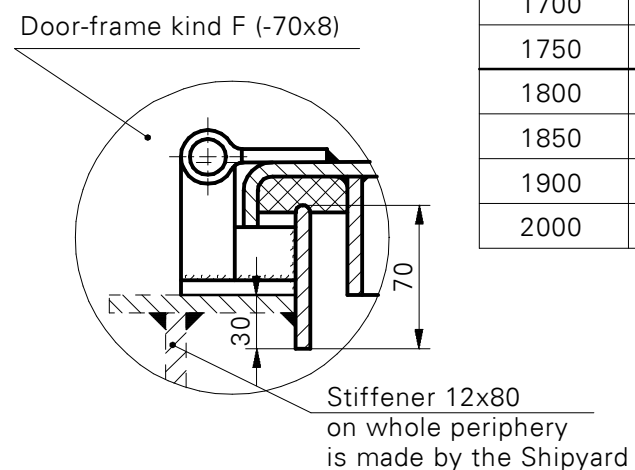
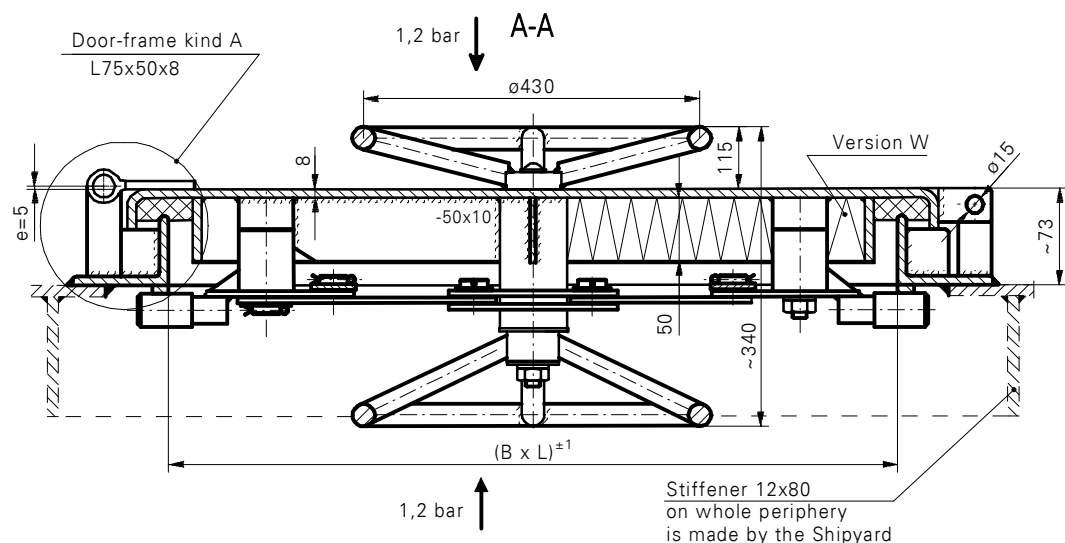
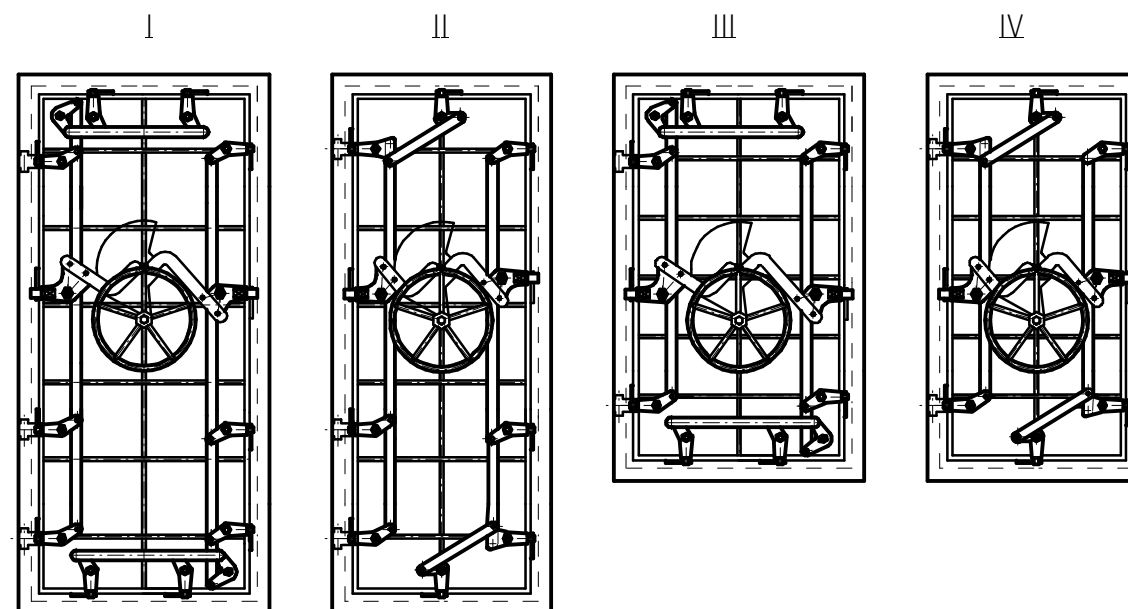

H Height	B Type						
	600	650	700	750	800	850	900
1400	IV	IV	IV	IV	III	III	III
1500	IV	IV	IV	IV	III	III	III
1600	IV	IV	IV	IV	III	III	III
1700	IV	IV	IV	IV	III	III	III
1750	IV	IV	IV	IV	III	III	III
1800	II	II	II	II	I	I	I
1850	II	II	II	II	I	I	I
1900	II	II	II	II	I	I	I
2000	II	II	II	II	I	I	I

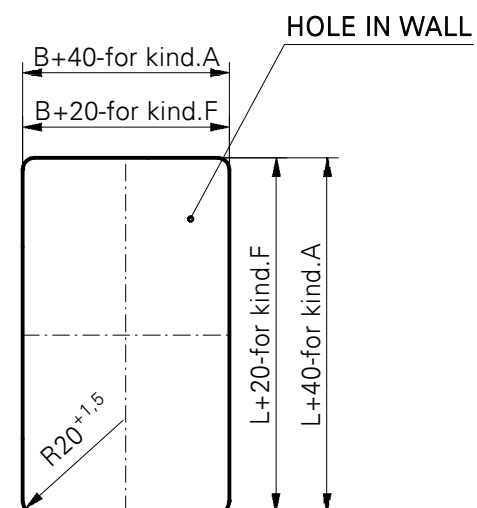

LUBMOR Ltd.

ul. Wieleńska 1, 64-980 Trzcianka
tel. +48/67/216-22-44
fax +48/67/216-59-40
e-mail: lubmor@lubmor.pl
www.lubmor.pl

**WATERTIGHT DOOR
to 1,2 bar**

**KK 24-07
34-945**

WATERTIGHT DOOR TO 1,2 bar

APPROPRIATION

This door is mainly designed for installation onboard in steel walls for pressure to 1,2 bar.

EXECUTION

Design of the door-leaf assure full stiffness by means the stiffeners of flat bar 40x8. There was used central closing of the door-leaf by means gear train. The elements which are exposed for friction (pins, sleeves) are made of stainless steel. The elements of closing devices are made of galv. steel. The hinges and closing devices are equipped with stainless steel grease nipples.

In case mounting rim lock with cylinder, hole for key is protected with watertight cover.

DELIVERY RANG

Delivery comprises complete door with fittings acc. to list as below.

DIVISION, MARKING AND FINISHING

Varieties :

- ST - steel
- SZ - galvanized
- SN - stainless steel

Kinds :

- R - as shown on drawing
- L - left as reflected

Kinds of the door-frames :

- A - door-frame shape – angle bar 75x50x8
- F - door-frame shape – flat bar 70x8

Kinds of the equipment :

- 1 - without equipment
- 2 - closure for padlock
- 3 - bolt rim lock
- 4 - catch closure

Kinds of the door-leaves :

- without insulation-without marking
- W - insulated door-leaf
- M - cover of closing device

Finishing :

- door-leaf and door-frame for varieties ST and SZ painted with epoxy primer of total thickness 40 µm. Channel under gasket is additionally painted with thick-epoxy paint of total thickness 120 µm.

Mal - door-leaf painted with set of stoove paints acc. to RAL catalogue

EXAMPLE OF MARKING

Watertight door to 1,2 bar of dim. 1750x750, steel, type IV, right-hand, frame of angle bar, closure for padlock, rim lock with cylinder, catch closure and cover of closing device, door-leaf painted acc. to RAL 8003.

WATERTIGHT DOOR TO 1,2 bar 1750x750 – ST –IV – R – A – 2 – 3 – 4 – WM – Mal 8003
acc. to catalogue card no **KK24-07/34-945**.

This catalogue card corresponds with drawing no N24-07/34-945.