

ASSEMBLY SYSTEM - SM I

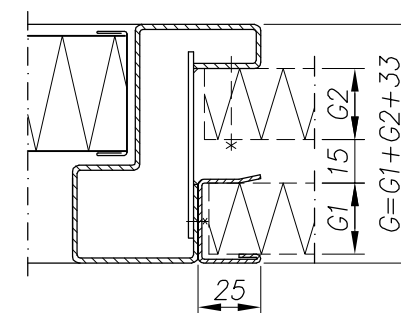

ASSEMBLY SYSTEM - SM II

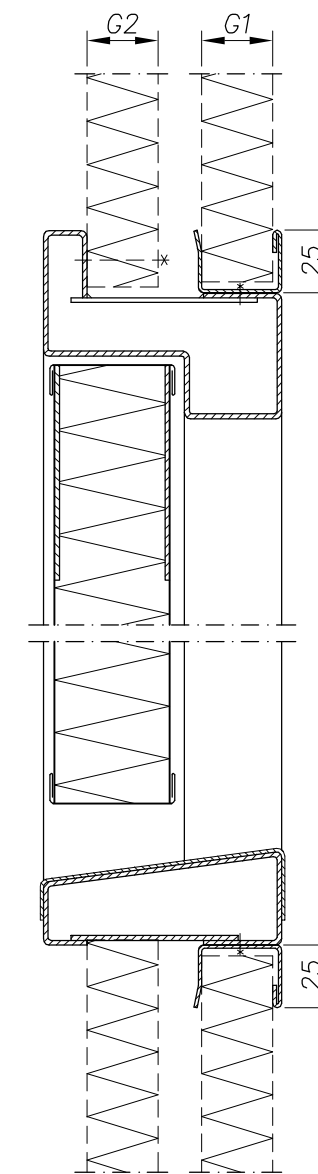
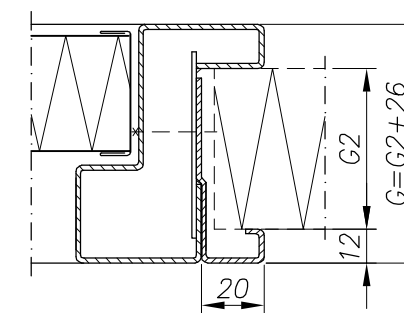
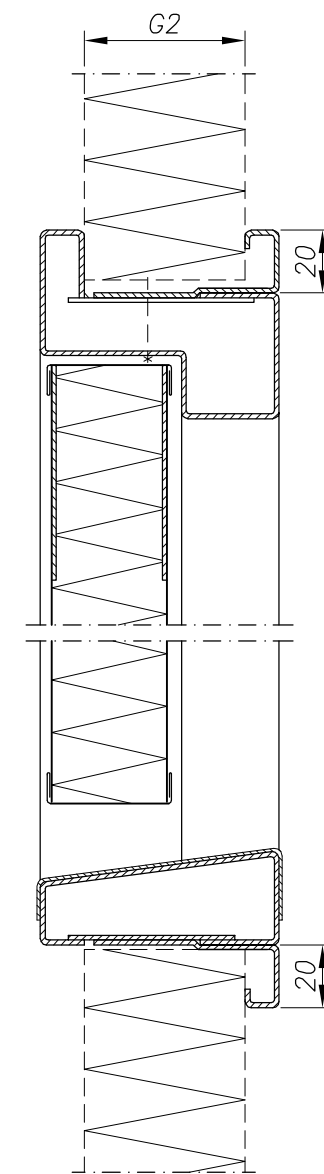

ASSEMBLY SYSTEM - SM III

H	B
1700	600
1750	650
1800	700
1850	750
1900	850
1950	900
2000	1000



LUBMOR Sp. z o.o.

ul. Wieleńska 1, 64-980 Trzcianka
 tel. +48/67/216-22-44
 fax +48/67/210-19-19
 e-mail: lubmor@lubmor.pl
www.lubmor.pl

**DOOR CLASS B15
 FOR SANITARY UNITS
 OPENED INSIDE**

**KK 24-12
 34-450/W**

DOOR CLASS B15 FOR SANITARY UNITS OPENED INSIDE

APPROPRIATION

The door class B15 is designed for closing of passages in inside accommodations (as a passage from cabin or corridor to sanitary unit) of required fire protection B15 on all floating objects.

EXECUTION

Door-frame is made of steel profile thick. 1,5 mm welded to form a frame. The door sill is protected with cover of stainless steel. Door-leaf is made of two cassettes of painted or PVC foiled galv. sheet thick. 0,7 mm and inside frame of profile. It is filled with mineral wool after assembly of two cassettes. Doors are equipped with mortise sanitary lock and hinges of stainless steel.

There are possible to individual introducing of dimensions and assembly system of the doors acc. To wishing a customer and with agreement with design office.

SYSTEM OF ASSEMBLY

- I - Door-frame is installed to the wall of sanitary unit of thick. G2. Two guides of shuttering with thick. G1 are installed on the sides of door-frame. The panels made of steel sheet thick. 1,5 mm and filled of mineral wool are installed over and under door-frame.
- II - Door-frame is installed to the wall of sanitary unit of thick. G2. Assembly frame made of steel sheet thick. 1,5 mm and suitable for installation shuttering wall of thick. G1 is installed on whole periphery of door-frame. Standard distance between the walls is 15 mm.
- III - Door-frame is installed to the wall of sanitary unit of thick. G2. Assembly frame made of steel sweet trick. 1,5 mm is installed on whole periphery of door-frame.

DELIVERY RANG

Delivery includes door with fittings but without fixing elements.

PACKING, TRANSPORT, STORAGE

Door-leaf is protected for transport and storage with cardboard. Edge of door-leaf and door-frame are protected with self-sticking tape. The goods are placed on the pallets with wooden separators, can be displaced by means of the cranes and fork-lift trucks. They must be stored in roofed accommodations.

DIVISION, MARKING AND FINISHING

Varieties :

- L - left-hand door (acc. to drawing)
- P - right-hand door (as reflected)

Fixing elements:

- U - height of panel over door
- D - height of panel under door
- G - depth of door-frame
- G1 - thickness of lining board
- G2 - thickness of wall of sanitary unit

Equipment :

- A - kick-out panel of dim. 420 mm x 550 mm
- W125 - small air grate - 125 cm²
- W250 - big air grate - 250 cm²
- Sz - door with sanitary lock-indicator at hinges side
- Sp - door with sanitary lock-indicator at the other side

Finishing of door-leaf :

- F - z/p – PCV covered steel sheet acc. to DOBEL or GISLAVED catalogue
- M - z/p – painted acc. to RAL catalogue
 - z – color from hinges side
 - p – color from the other side

Finishing profile on the door-leaf – as cassette of the door-leaf at hinges side

Finishing of door-frame and assembly profiles :

- M - painted acc. to RAL catalogue

EXAMPLE OF DESIGNATION

Door class B15 for sanitary unit clear opening H x B - 1750 x 600, left-hand variety (**L**), with sanitary lock and indicator at the other side (**Sp**), with kick-out panel (**A**), with small air grate (**W125**), door-leaf made of PVC steel sheet (**F**), 1072 – color from hinges side (**z**), 1254 – color from the other side (**p**); door-frame, guides and panels painted (**M**) acc. to RAL 1013; assembly system **SM-I**: panel over door U=150 mm, panel under door D=100 mm, lining board G1 = 25mm, wall of sanitary unit G2 = 25mm.

DOOR CLASS B15 1750 x 600-LSpAW125-F z1072/p1254-M1013, SM-I, U=150, D=100, G1=25, G2=25 acc. to catalogue card no **KK24-12/34-450/W**.

This catalogue card corresponds with drawing no N24-09/34-450 and working drawing no N24-09/34-450/W.