

Type I

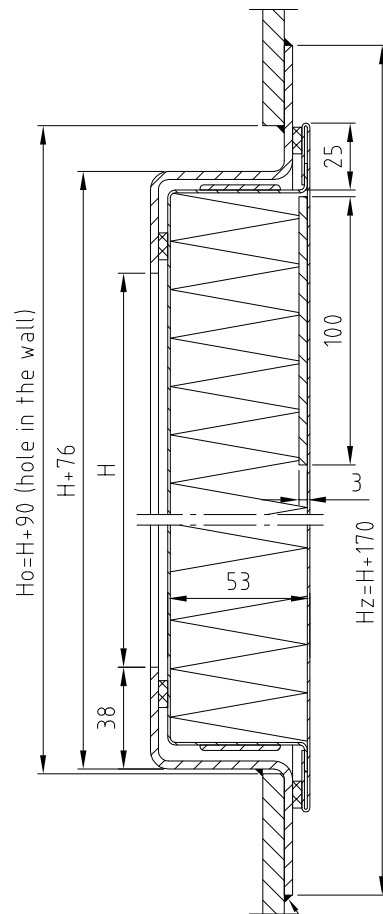

Type II

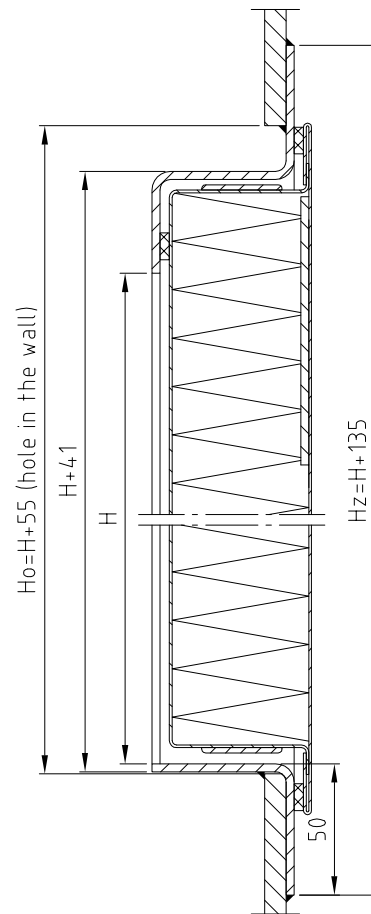

Type III

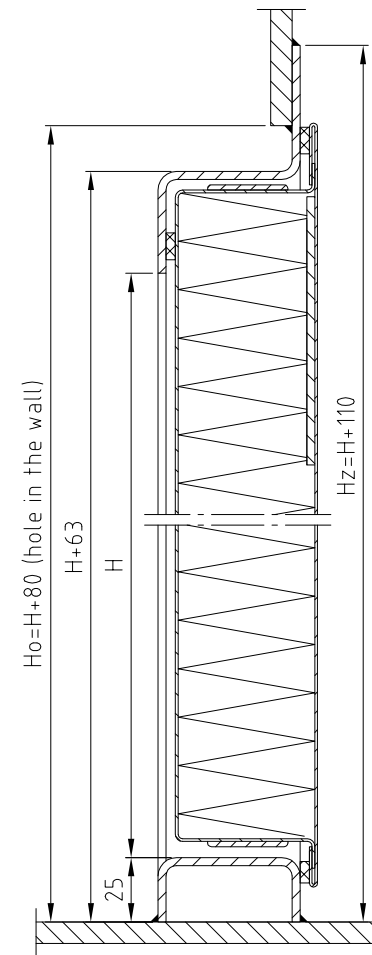

3 nx25(200)
3 nx25(200)

Bo=B+115 (hole in the wall)

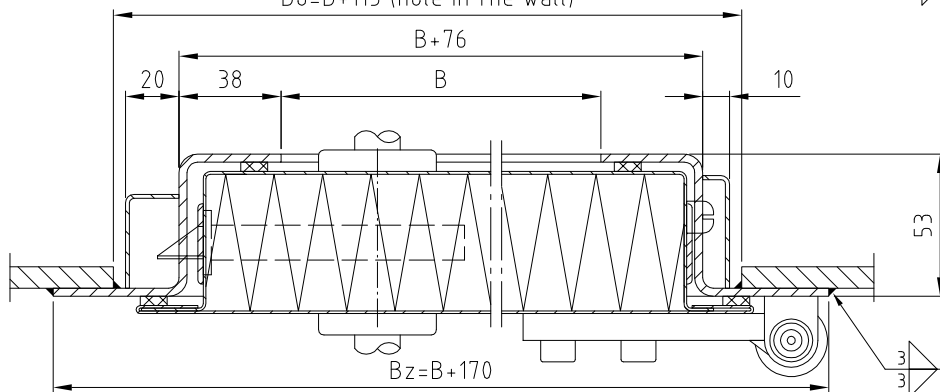

3 nx25(200)
3 nx25(200)

NOTE:

1. Drawing for variation P-right, variety L-left, as a mirror image.



LUBMOR Ltd

Wieleńska 1 Str., 64-980 Trzcianka
 phone +48/67/216-22-44
 fax +48/67/216-59-40
 e-mail: lubmor@lubmor.pl
 www.lubmor.pl

Door mass ~38,5kg/m²

**DOOR CLASS A0-A30
 GAS-TIGHT**

**KK24-20
 34-743/C**

DOOR CLASS A0-A30 GAS-/WEATHER-TIGHT

APPROPRIATION

The door class A0-A30 is designed for closing the passageways in fire proof divisions, engine casings and stair closures of required fire protection A0-A30 inside all float and land objects. The gas-/weather-tightness of the door was confirmed by Bureau Veritas through a water tightness test carried out with a fire hose with the following parameters: p = 0.2 MPa, distance-1.5 m, nozzle diameter 12 mm (certificate **2156PZN19**).

The door to be welded to the bulkhead class A.

EXECUTION

Specially profiled door – frame is made of 3 mm cold rolled stress free steel plate. In standard door-frame is painted with primer paint. The door – leaf is made of two cassettes of steel sheet as a box construction. The inside and outside cassettes form a closed space which is insulated of mineral wool. Inside door – leaf has also a steel frame made of channel profile. Mineral wool ensures thermal insulation of the door – leaf. A gasket which allow to reach a gas-tightness of the door is glued around of the door-leaf, and the door-frame. A gasket is supplied loose and glued (installed) after the door is welded.

Design of the door – leaf allows to make it in varieties as below :

- painted of stove enamels (M),
- covered of PVC foiled galvanized steel sheet (D).

The door is equipped with mortise lock, two hinges and two anti-prize pins. Stiffening top part of the door – leaf with 3mm steel plate allow to mount a self – closing devices and an electromagnetic door holders. The door can be made with the pass for fire hose of dimensions 150x150 mm. The door in the pass is hanged on stainless steel spring hinge. An expanding strip is glued around the entire perimeter of the door-leave.

DELIVERY RANG

Delivery rang includes the doors without self – closing devices, electromagnetic door holders and patent cylinders. Gas-/weather-tight gasket supplied loose.

PACKING, TRANSPORT, STORAGE

The doors are protected against mechanical damages and can be easy transported. The goods are placed on the pallets with wooden separators, can be displaced by means of the cranes and fork – lift trucks. They must be stored in roofed accommodations.

DIVISION, MARKING AND FINISHING

Varieties :

- P - right hand door - acc. to drawing
- L - left hand door - as reflected

Types (dependable on the sill) :

- I - door with standard sill
- II - door with high sill
- III - door with lower sill

Kinds of the door – leaves (dependable on door – leaf finishing) :

- M - z/p - door – leaf painted acc. to RAL catalogue
- D - z/p - door – leaf covered with decorative plate of PVC foil acc. to DOBEL or GISLAVED catalogue
 - z - colour from hinge side
 - p - colour from the other side

Equipment :

- door with full lock plate (without marking)
- Wp - door with lock plate suitable for cylinder

EXAMPLE OF DESIGNATION

The door class A0 gas-tight clear opening HxB – 1800x800, right – hand variety (**P**), with door plate suitable for cylinder (**Wp**), with welded door – frame and painted with a primer (**Z**), door with standard sill (**I**), door-leaf covered of PVC foil (**D**), from hinges side (**z**) colour 1205, from the other side (**p**) colour 1340.

DOOR CLASS A0 GAS-TIGHT 1800x800-P-Wp-Z-I-D z1205/p1340 acc. to catalogue card no **KK24-20/34-743/C**.

This catalogue card corresponds with drawing no N24-20/34-743 and working drawing no N24-20/34-743/C .